

Innovation 2013

The new 25MT C360 model is the first Diesel all road mini crane without stabilizers with an extra variable wheelbase, «pick and carry" on 360°. This crane is conceived to operate on confined and rough terrain.

Its variable wheelbase passes from 1m41 to 2m56, an innovation!

Without stabilizers the crane could move with the load suspended on the lateral side.

The crane is equipped with a 31,2 KW diesel engine and rubber trucks.

It integrates a jib with a double hydraulic telescope with a big bearing distance. The crane could be equipped with a hydraulic jib (length 1300/2100 mm).

It uses a **3-cylinder kinematic system** developed by **Mobilev Cranes** allowing for greater angular motion of the jib.

Lastly, the 25MT C360 may also be equipped with the **“hydraulic winch” option**. Ideally installed on the mini-crane, the cable runs inside the jib for optimum safety, which is an innovation by **Mobilev Cranes**.



Patented model

Technical specifications



Maxi load	2500 kg
Unladen weight (without options)	4000 kg
Admissible slope (unladen crane)	40 %
Displacement speed	2.5 or 4.7 km/h
Adjustable lifting speed	0 to ... cm/s
Adjustable telescoping speed	0 to... cm/s
Turret speed	0 to ... tr/min
Diesel engine Deutz Phase IIIA 31 kW à 2300 tr/min	
LS pump, variable flow from	0 to 160 l/min
Fuel tank capacity	50 L

Standard equipment

- Interchangeable rubber tracks
- Two-speed traction motor (open circuit)
- Hydraulic variable wheelbase (1m41 -> 2m56)
- Crutches hydraulic lifting
- 360° turret (non continuous movement)
- Anti-tilt system with 2 axes bank indicator
- Automatic braking system
- Automatic parking brake
- Radiator cooling (hydraulic oil)
- Hydraulic rescue levers
- Color control display 7 " IP67
- Electronic controller
- Three colored signalling system
- Starter and Alternator
- 2x12V starter batteries
- 24V Spot light

Main options

- Hydraulic additional JIB 1300/2100 mm
- Hydraulic winch 1000/2000 kg
- Paddle level proportional remote control

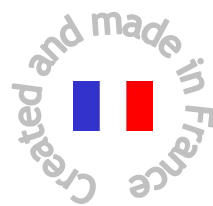

Mobilev Cranes

PA des Grandes Terres
1305 route de Lozanne
69 380 DOMMARTIN - FRANCE

Tél: +33 (0)4 72 88 21 05

E-mail: mobilev@mobilev-cranes.com
www.mobilev-cranes.com

Technical sheet 25MT C360

« All-road » self-propelled mini-crane with accompanying operator

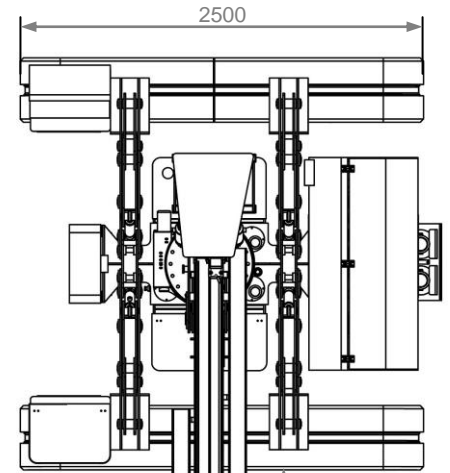
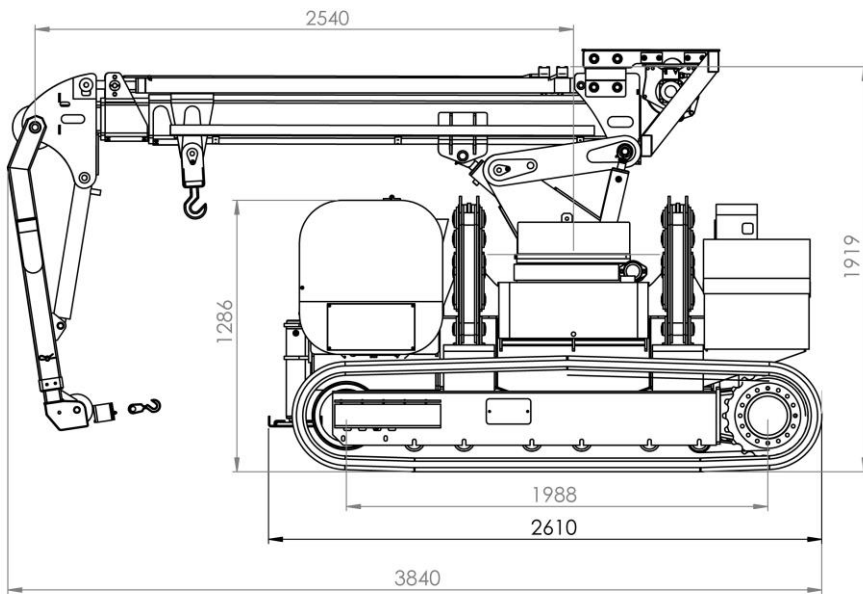

Dashboard
With color control display
7" IP67



Tableau 8 : Charges nominales en kg pour chaque configuration



Angle	Config 1	Config 2	Config 3	Config 4	Config 5	Config 6
0	2 600	2 160	1 100	305	203	184
10	2 600	2 160	1 100	311	207	187
20	2 600	2 160	1 100	345	229	208
30	2 600	2 160	1 100	401	267	242
40	2 600	2 160	1 100	486	323	293
50	2 600	2 160	1 100	588	391	354
60	2 600	2 160	1 100	524	349	316
70	2 600	2 160	1 100	475	316	286
80	2 600	2 160	1 100	401	267	242
90	2 600	2 160	1 100	322	214	194
100	2 600	2 160	1 100	350	233	211
110	2 600	2 160	1 100	469	312	283
120	2 600	2 160	1 100	551	367	332
130	2 600	2 160	1 100	669	445	403
140	2 600	2 160	1 100	514	342	310
150	2 600	2 160	1 100	418	278	252
160	2 600	2 160	1 100	322	214	194
170	2 600	2 160	1 100	271	180	163
180	2 600	2 160	1 100	283	188	170

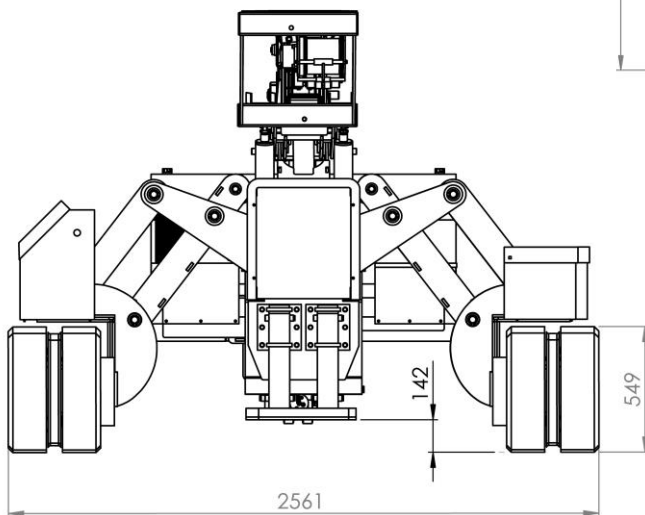
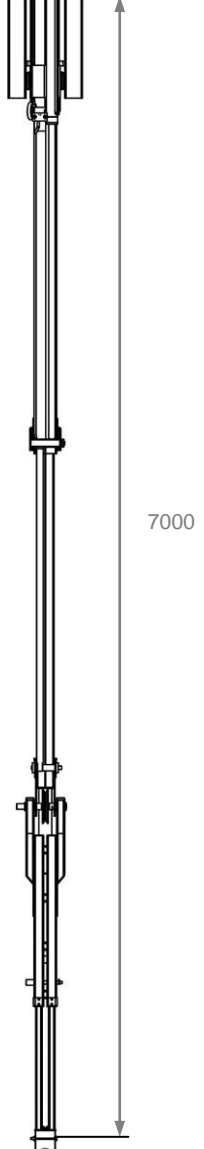
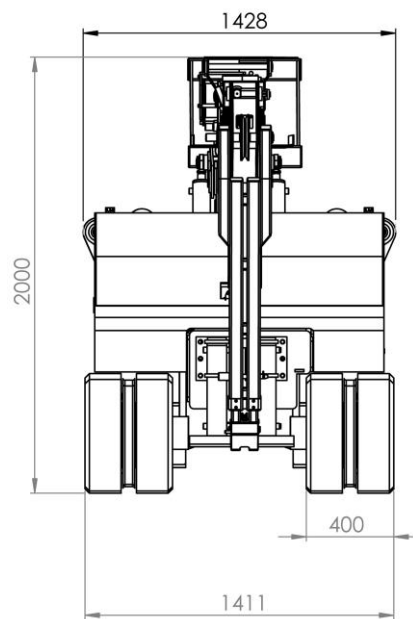
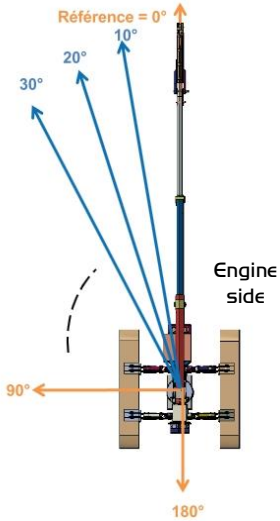

☺ Most favorable angles

Non-contractual values, tests are in progress



Paddle level proportional remote control

